

## FH429 | SIGNATURE CHAIR - Design: Frits Henningsen



### DESCRIPTION

- The Signature Chair was the last piece of furniture Frits Henningsen designed and produced. Carl Hansen & Son is now recreating this unique work by one of Danish design's most renowned 20<sup>th</sup> century personalities.
- The Signature Chair (product code FH429) is available with a solid oak or walnut frame in various finishes and with leather or fabric upholstery. The chair's dimensions are 41 cm (seat height), 102 cm (height), 89 cm (depth) and 67 cm (width).

---

### HISTORY

- The Signature Chair was finally complete in 1954, and fewer than 20 pieces were produced. It is therefore an extremely rare piece of furniture and not often seen at auctions. On the rare occasions it does appear, the chair is highly sought after among collectors and has often sold for large sums in recent years.
- A cabinetmaker who held his profession to very high standards, Frits Henningsen always produced his own designs. He often began the process by creating a small model. The Signature Chair, for example, was designed with the aid of plasticine, with toothpicks standing in for legs.

---

### THE DESIGNER

**Frits Henningsen** (1889-1965) was known as an uncompromising designer. He viewed quality craftsmanship as the most important element of his work, making it his focus when developing new furniture. Unlike other cabinetmakers, Henningsen always created his own furniture pieces - although his greatest desire was to be recognized as a cabinetmaker and not as a furniture designer.

After he opened his own furniture store in Copenhagen, he drew much inspiration from contact with customers, using daily conversations to better understand demand and apply this directly to the production process.

At age 22, he completed his cabinetmaker apprenticeship with one of the most recognized cabinetmakers of his day, I.P. Mørck. Like many of his creative elite contemporaries, Henningsen then traveled around Europe to gather experience and inspiration, working in Germany, France and Great Britain for several years before returning to Copenhagen in 1915.

In his designs, Henningsen was able to capture traditional expressions from other style periods and reinterpret them with a modern and organic flavor. He drew inspiration from earlier styles such as French Empire, Rococo, and British 17th-century furniture, much like one of the other great furniture designers of his day, Kaare Klint. The two designers met at technical college, where Kaare Klint was one of Frits Henningsen's teachers.

This encounter had a major influence on **Frits Henningsen's** development as a cabinetmaker, while the competition that arose between the two men led to a constant renewal and reinterpretation of furniture craftsmanship by both parties.

**Frits Henningsen** saw himself as constantly developing and, due to his great attention to detail, permitted only very few of his furniture pieces to be produced outside his own workshop. During **Frits Henningsen's** lifetime, Carl Hansen & Son was one of only two furniture producers to be shown such trust. Carl Hansen & Søn manufactured Frits Henningsen's Windsor Chair for over 70 years and re-launched his **Heritage Chair** (<http://www.youtube.com/embed/8vAVbY4bpo8?rel=0>) in 2013.

---

Experience Frits Henningsen's Heritage Chair

(<http://www.carlhansen.com/products/lounge-chairs/fh419/>)

Watch the craftsmanship going into the making of the Heritage Chair

(<http://www.youtube.com/embed/8vAVbY4bpo8?rel=0>)

---

## VARIANTS CHOICES AND DIMENSIONS

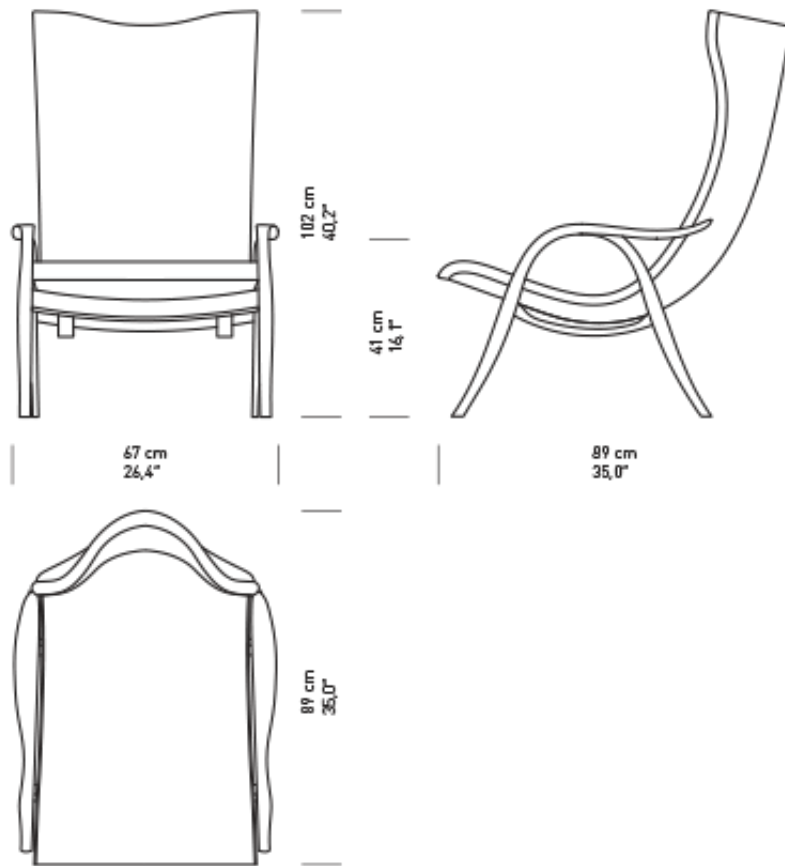

---

## MATERIAL MATRIX

	Soap	Lacquer	Oil	White oil
Oak	●	●	●	●
Walnut		●	●	

---

## ENVIRONMENTAL INFORMATION

Carl Hansen & Søn and sustainability

People's fascination of the combination of good design and wood, as well as other natural materials, is something that transcends time and fashion. At Carl Hansen & Søn, we believe that this fascination helps to explain the great interest in our furniture, and we take very seriously concerns about the sustainability of the natural resources upon which we depend for our products. That is why we strive every day to improve our production methods, logistics and sales efforts in respect of scarce natural resources.

We buy wood only from sustainably managed forests. All sourced wood meets EUTR 2013 regulations, Danish Forest Legislation and current international certifications. Oak, beech and ash come primarily from Danish forests which are managed according to the principles described in Denmark's National Forest Programme; some of these wood types are also sourced from other

similarly managed European forests, or, in the case of walnut and cherry, North American forests.

We use every possible bit of these fine hardwoods in our furniture production. Inevitably, however, there are some scraps, which are then used to produce other products or recycled in district heating plants.

---

## **TESTS AND CERTIFICATIONS**

All tests and certificates are available on request.

---

## **CONTACT INFORMATION**

### **EUROPE**

#### **Carl Hansen & Søn A/S**

Hylkedamvej 77-79  
DK 5591 Gelsted  
Denmark

Tel: +45 66 12 14 04  
info@carlhansen.com

#### **Carl Hansen & Søn Flagship Store**

Bredgade 18, 21 & 23  
1260 Copenhagen K  
Denmark

Opening Hours:  
Monday-Friday: 11.00-18.00  
Saturday: 10.00 - 15.00

Phone: +45 64 47 23 60  
retail@carlhansen.dk

#### **Carl Hansen & Søn Showroom Oslo**

Drammensveien 130 B9  
0277 Oslo  
Norway

+47 900 77 087  
hrs@carlhansen.dk

#### **Carl Hansen & Søn Showroom London**

16A Bowling Green Lane  
London  
EC1R 0BD  
United Kingdom

Tel: +44 (0) 20 7632 7587  
Mail: ukinfo@carlhansen.com

### **Carl Hansen & Søn Italy SRL**

Showroom Milan  
Foro Buonaparte 18/A/ Via Arco 4  
20121 Milan  
Tel: +39 02 89011837

Area Manager Southern Europe  
Ottorino Castegnaro  
Tel: +39 340 4266636  
Mail: oc@carlhansen.dk

### **AMERICA**

#### **Carl Hansen & Søn Showroom New York**

251 Park Avenue South  
13th Floor  
New York, NY 10010

Tel: +1 212 242 6736

Customer Service: Northamerica@carlhansen.com

Contract Sales:

[Contract contact information US](http://www.carlhansen.com/contract-contact-information-us/)

(<http://www.carlhansen.com/contract-contact-information-usa/>)

Thomas Vagner, President: tv@carlhansen.com

Angela Patsiopoulos, Director of Retail Sales: ap@carlhansen.com

#### **Carl Hansen & Søn Showroom Los Angeles**

8745 Washington Boulevard  
Studio B  
Culver City, CA 90232  
Tel.: + 1 (310) 842-8656

### **ASIA/PACIFIC**

#### **Carl Hansen & Søn Japan K.K.**

2F Hills Aoyama, 3-39-9 Jingumae  
Shibuya-ku 150-0001  
Tokyo, Japan

Tel: +81 3 5413 6771  
Fax: +81 3 5413 6772  
info@carlhansen.jp

**Carl Hansen & Søn Flagship Store Japan**

Aoyama Artworks 1/2F  
2-5-10 Jingumae  
Shibuya-ku, Tokyo, 150-0001  
Japan  
+81 3 5413 5421

Opening hours

Mon-Fri: 11 am- 8 pm

Sat. Sun. and

National Holidays: 12 a m - 7pm

**Carl Hansen & Søn Asia Pacific Limited**

16th Floor, 202 Centre  
202-204 Des Voeux Road West  
Hong Kong

Tel: +852 563 10267

Mail: [asiainfo@carlhansen.dk](mailto:asiainfo@carlhansen.dk)

**Carl Hansen & Søn China**

570 Yongjia Road, Surpass Court Building 5 Room 501  
Xuhui District, Shanghai  
China, 200030

Tel: +86 15000390978

Mail: [chinainfo@carlhansen.dk](mailto:chinainfo@carlhansen.dk)