

E016 | EMBRACE FOOTSTOOL - Design: EOOS



DESCRIPTION

- Embrace Footstool (E016) is part of the Embrace series, which also comprises Embrace Lounge Chair and Embrace Chair. Design-wise, the chair appears precise while radiating casual elegance.
- The footstool is the ideal partner for the Embrace Lounge Chair, or can stand alone as a sculptural alternative to a coffee or side table, while also serving as a practical extra seat.
- Embrace Footstool is available in solid oak or walnut with different surface treatments, and upholstered in leather or fabric. Upholstery and edge trims are available in a range of variants and combinations.
- The Embrace Chair (E005), Embrace Lounge Chair (E015) and Embrace Footstool (E016) are all available with solid oak or walnut frames in various finishes and can be upholstered in leather or fabric with white, natural, blue, brown or black trim.

HISTORY

EMBRACE SERIES

EOOS and Carl Hansen & Søn have joined forces to create a series of chairs that unite EOOS' strong sense of modern aesthetics with Carl Hansen & Søn's tradition of high-quality craftsmanship and outstanding comfort. The results are the Embrace Chair and the Embrace Lounge Chair: two designs that couple the ultimate in easygoing style with compelling design. The design trio has designed a matching footstool as well, the Embrace Footstool.

THE DESIGNER

Established in Vienna, the EOOS trio is comprised by Gernot Bohmann, Harald Gründl and Martin Bergmann. Founded in a strong sense of modern aesthetics, EOOS operates in the fields of furniture and product design as well as shop design for clients such as Giorgio Armani, Adidas, Alessi, the Bill & Melinda Gates Foundation and bulthaup.

The design trio considers design a poetic discipline whose end result should always be able to accommodate the user's changing needs and desires. EOOS approaches the often-complex design challenges by analyzing past roots and contemporary context. Termed 'Poetical Analysis', EOOS' process focuses on myths, rituals and intuitive expressions, creating connections that go beyond immediate impressions.

In 2015 Austrian Museum of Applied Arts / Contemporary Art celebrated the work of EOOS with the first major solo exhibition. Alongside their numerous international awards, EOOS has over 15 technical patents to date. In 2007, the Austrian Broadcasting Corporation (ORF) and the readers of the daily newspaper "Die Presse" nominated the EOOS-founders "Austrians of the Year" in the Creative Industries.

VARIANTS CHOICES AND DIMENSIONS

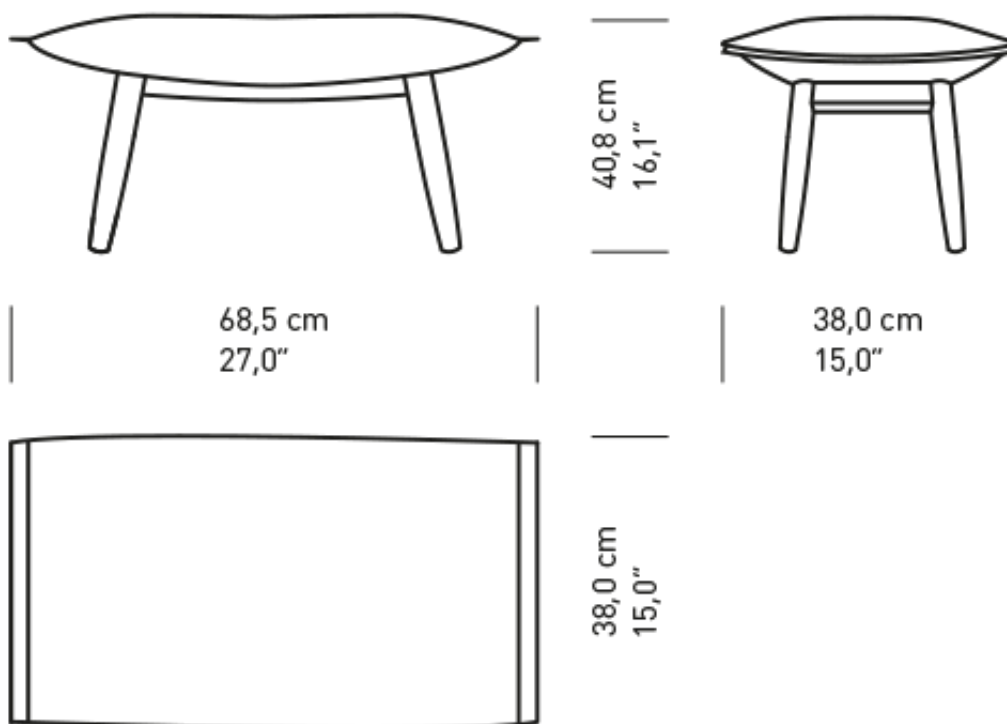

MATERIAL MATRIX

	Soap	Lacquer	Oil	White oil	Black paint
Oak	●	●	●	●	●
Walnut		●	●		

ENVIRONMENTAL INFORMATION

Carl Hansen & Søn and sustainability

People's fascination of the combination of good design and wood, as well as other natural materials, is something that transcends time and fashion. At Carl Hansen & Søn, we believe that this fascination helps to explain the great interest in our furniture, and we take very seriously concerns about the sustainability of the natural resources upon which we depend for our products. That is why we strive every day to improve our production methods, logistics and sales efforts in respect of scarce natural resources.

We buy wood only from sustainably managed forests. All sourced wood meets EUTR 2013 regulations, Danish Forest Legislation and current international certifications. Oak, beech and ash come primarily from Danish forests which are managed according to the principles described in Denmark's National Forest Programme; some of these wood types are also sourced from other similarly managed European forests, or, in the case of walnut and cherry, North American forests.

We use every possible bit of these fine hardwoods in our furniture production. Inevitably, however, there are some scraps, which are then used to produce other products or recycled in district heating plants.

TESTS AND CERTIFICATIONS

All tests and certificates are available on request.

CONTACT INFORMATION

EUROPE

Carl Hansen & Søn A/S

Hylkedamvej 77-79

DK 5591 Gelsted

Denmark

Tel: +45 66 12 14 04

info@carlhansen.com

Carl Hansen & Søn Flagship Store

Bredgade 18, 21 & 23

1260 Copenhagen K

Denmark

Opening Hours:

Monday-Friday: 11.00-18.00

Saturday: 10.00 - 15.00

Phone: +45 64 47 23 60

retail@carlhansen.dk

Carl Hansen & Søn Showroom Oslo

Drammensveien 130 B9

0277 Oslo

Norway

+47 900 77 087

hrs@carlhansen.dk

Carl Hansen & Søn Showroom London

16A Bowling Green Lane

London

EC1R OBD

United Kingdom

Tel: +44 (0) 20 7632 7587

Mail: ukinfo@carlhansen.com

Carl Hansen & Søn Italy SRL

Showroom Milan

Foro Buonaparte 18/A/ Via Arco 4

20121 Milan

Tel: +39 02 89011837

Area Manager Southern Europe

Ottorino Castegnaro

Tel: +39 340 4266636

Mail: oc@carlhansen.dk

AMERICA

Carl Hansen & Søn Showroom New York

251 Park Avenue South

13th Floor

New York, NY 10010

Tel: +1 212 242 6736

Customer Service: Northamerica@carlhansen.com

Contract Sales:

Contract contact information US

(<http://www.carlhansen.com/contract-contact-information-usa/>)

Thomas Vagner, President: tv@carlhansen.com

Angela Patsiopoulos, Director of Retail Sales: ap@carlhansen.com

Carl Hansen & Søn Showroom Los Angeles

8745 Washington Boulevard
Studio B
Culver City, CA 90232
Tel.: + 1 (310) 842-8656

ASIA/PACIFIC

Carl Hansen & Søn Japan K.K.

2F Hills Aoyama, 3-39-9 Jingumae
Shibuya-ku 150-0001
Tokyo, Japan

Tel: +81 3 5413 6771
Fax: +81 3 5413 6772
info@carlhansen.jp

Carl Hansen & Søn Flagship Store Japan

Aoyama Artworks 1/2F
2-5-10 Jingumae
Shibuya-ku, Tokyo, 150-0001
Japan
+81 3 5413 5421

Opening hours

Mon-Fri: 11 am- 8 pm

Sat. Sun. and

National Holidays: 12 a m - 7pm

Carl Hansen & Søn Asia Pacific Limited

16th Floor, 202 Centre
202-204 Des Voeux Road West
Hong Kong

Tel: +852 563 10267
Mail: asiainfo@carlhansen.dk

Carl Hansen & Søn China

570 Yongjia Road, Surpass Court Building 5 Room 501
Xuhui District, Shanghai
China, 200030

Tel: +86 15000390978

Mail: chinainfo@carlhansen.dk