

**ML10097 | Egyptian Table - Design:
Mogens Lassen**



DESCRIPTION

The elegant Egyptian Table easily collapses for storage with the release of a small brass sliding latch beneath the tabletop - a flexible design that exemplifies the functionalism inherent in classic furniture types. For Lassen and his contemporaries, function was paramount. Their approach - strongly influenced by Kaare Klint - often began with the careful study and refinement of long-existing archetypes such as safari-style knockdown chairs, British Windsor and Chippendale chairs, and flexible, practical tables like the Egyptian Table.

These clear, proven furniture types appealed to mid-century design and architecture visionaries, upholding their core belief that intelligent, purposeful design never goes out of style.

The base is crafted from solid wood and features a veneered table top.

THE DESIGNER

Having trained as a bricklayer in 1919-23, Mogens Lassen was admitted to the Royal Danish Academy of Fine Arts' School of Architecture, but also trained at a number of drawing offices with, among others, Danish architect Tyge Hvass in 1925-34.

A trip to Paris in 1927-28 sparked Lassen's interest in Le Corbusier's ideas about the home as a tool for a freer lifestyle. Introducing mezzanine floors in high-ceilinged rooms, for example, offered one way to free the home from the constraints of habitual thinking.

Applying a similar, experimental approach, Lassen designed homes where both function as well as the daylight flooding in through the windows shaped the rooms, and where outdoor spaces were just as carefully designed as the interiors.

As an architect for "The Permanent Exhibition of Danish Applied Arts and Industrial Design" in Copenhagen in 1939-67, Mogens Lassen was behind a number of exhibitions whose style of presentation helped Danish applied art win international recognition.

In addition to his many projects, villas, high-rise buildings, sports complexes and shop interiors, he designed furniture, furnishings and furnishing accessories.

Even if his steel furniture pieces from the 1930s are original examples of the innovations of international modernism, it is, above all, his pieces of simple, functional wooden furniture, like his folding Egyptian coffee table, that have gone on to become furniture classics.

In 1971, Mogens Lassen was awarded the C.F. Hansen Medal

VARIANTS CHOICES AND DIMENSIONS

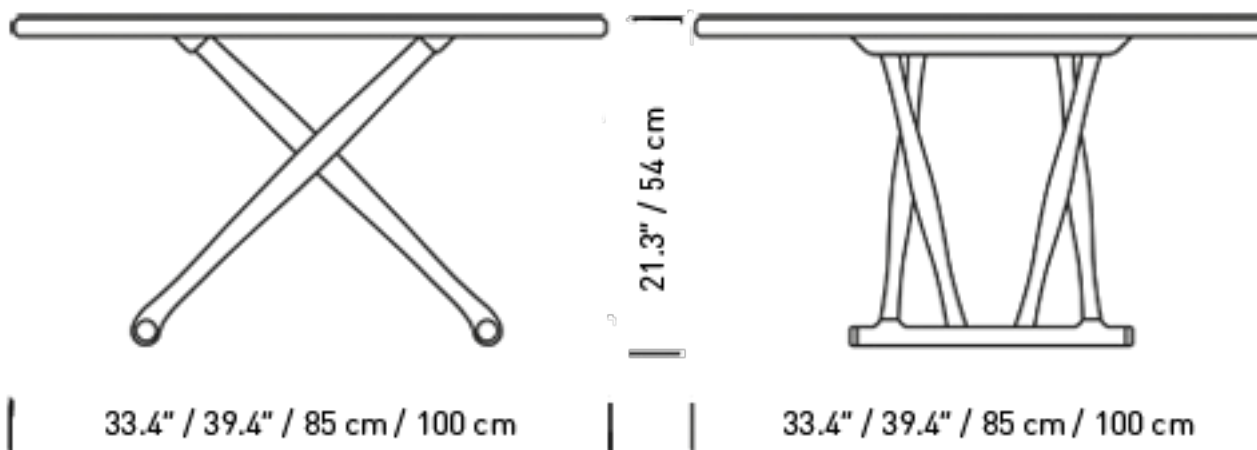

MATERIAL MATRIX

	Oil	White oil	Lacquer
Oak	●	●	●
Walnut	●		●

ENVIRONMENTAL INFORMATION

Carl Hansen & Søn and sustainability

People's fascination of the combination of good design and wood, as well as other natural materials, is something that transcends time and fashion. At Carl Hansen & Søn, we believe that this fascination helps to explain the great interest in our furniture, and we take very seriously concerns about the sustainability of the natural resources upon which we depend for our products. That is why we strive every day to improve our production methods, logistics and sales efforts in respect of scarce natural resources.

We buy wood only from sustainably managed forests. All sourced wood meets EUTR 2013 regulations, Danish Forest Legislation and current international certifications. Oak, beech and ash come primarily from Danish forests which are managed according to the principles described in Denmark's National Forest Programme; some of these wood types are also sourced from other similarly managed European forests, or, in the case of walnut and cherry, North American forests.

We use every possible bit of these fine hardwoods in our furniture production. Inevitably, however, there are some scraps, which are then used to produce other products or recycled in district heating plants.

TESTS AND CERTIFICATIONS

All tests and certificates are available on request.

CONTACT INFORMATION

EUROPE

Carl Hansen & Søn A/S

Hylkedamvej 77-79

DK 5591 Gelsted

Denmark

Tel: +45 66 12 14 04
info@carlhansen.com

Carl Hansen & Søn Flagship Store

Bredgade 18, 21 & 23
1260 Copenhagen K
Denmark

Opening Hours:
Monday-Friday: 11.00-18.00
Saturday: 10.00 - 15.00

Phone: +45 64 47 23 60
retail@carlhansen.dk

Carl Hansen & Søn Showroom Oslo

Drammensveien 130 B9
0277 Oslo
Norway

+47 900 77 087
hrs@carlhansen.dk

Carl Hansen & Søn Showroom London

16A Bowling Green Lane
London
EC1R OBD
United Kingdom

Tel: +44 (0) 20 7632 7587
Mail: ukinfo@carlhansen.com

Carl Hansen & Søn Italy SRL

Showroom Milan
Foro Buonaparte 18/A/ Via Arco 4
20121 Milan
Tel: +39 02 89011837

Opening Hours:

Monday: 14.00-19.00

Tuesday-Friday: 10.00 - 19.00

Saturday: 10.00 - 18.00

Sunday: closed

Area Manager Southern Europe

Ottorino Castegnaro

Tel: +39 340 4266636

Mail: oc@carlhansen.dk

AMERICA

Carl Hansen & Søn Showroom New York

251 Park Avenue South

13th Floor

New York, NY 10010

Tel: +1 212 242 6736

Customer Service: Northamerica@carlhansen.com

Contract Sales:

Contract contact information US

(<https://www.carlhansen.com/contract-contact-information-usa/>)

Thomas Vagner, President: tv@carlhansen.com

Angela Patsiopoulos, Director of Retail Sales: ap@carlhansen.com

Carl Hansen & Søn Showroom Los Angeles

8745 Washington Boulevard

Studio B

Culver City, CA 90232

Tel.: + 1 (310) 842-8656

ASIA/PACIFIC

Carl Hansen & Søn Japan K.K.

2F Hills Aoyama, 3-39-9 Jingumae

Shibuya-ku 150-0001
Tokyo, Japan

Tel: +81 3 5413 6771
Fax: +81 3 5413 6772
info@carlhansen.jp

Carl Hansen & Søn Flagship Store Japan

Aoyama Artworks 1/2F
2-5-10 Jingumae
Shibuya-ku, Tokyo, 150-0001
Japan
+81 3 5413 5421

Opening hours

Mon-Fri: 11 am- 8 pm
Sat. Sun. and
National Holidays: 12 a m - 7pm

Carl Hansen & Søn Asia Pacific Limited

16th Floor, 202 Centre
202-204 Des Voeux Road West
Hong Kong

Tel: +852 563 10267
Mail: asiainfo@carlhansen.dk

Carl Hansen & Søn China

570 Yongjia Road, Surpass Court Building 5 Room 501
Xuhui District, Shanghai
China, 200030

Tel: +86 15000390978
Mail: chinainfo@carlhansen.dk

