



—
Balloons
Shadows
Muffins
Memory
Capsula
Mona
Whistle
—

BROOKIS

BROKIS
DESIGN BY
LUCIE KOLDOVA
DAN YEFFET
BORIS KLIMEK



BALLOONS

— A collection of simple yet timeless lamps based on a transparent, nearly invisible balloon with a hovering reflector to serve as an elegant and stately source of light in any setting. The clean appearance of the transparent balloons is underlined by the natural beauty of the quality hand-blown glass. The collection features a small table model and two free-standing models. The size of the largest Balloon shade is the embodiment of exceptional glassblowing craftsmanship, as it pushes the technique to its very limits. —



COLOUR

GLASS/BASIC

(glossy CGSU 66)
CGC 23 transparent
CGC 516 smoke grey

SPOTLIGHT/BASIC

CCS 575 white
CCS 613 lemon yellow
CCS 582 black
CCS 574 reflective orange
CCS 583 gold

SPOTLIGHT/ADD

CCS 584 copper
CCS 69 brass

TEXTILE CABLES

CECL 521 white
CECL 519 black
CECL 530 red
CECL 520 grey
CECL606 yellow









Paying homage to its typological heritage, the Shadows collection is a new take on the recognized and timeless French atelier pendant spot light. The five-lamp clusters feature different types of glass shade that slide over a wooden neck. The variable fittings allow you to apply your own creativity in composing new lighting experiences every day, while the purity of form is underscored by the hidden light source – a warm LED spotlight.

SHADOWS





COLOUR

GLASS/BASIC

(glossy CGSU 66 and acid-etched CGSU 67)
CGC 39 triplex opal

GLASS/STANDARD

(glossy CGSU 66 and acid-etched CGSU 67)
CGC 516 smoke grey
CGC 538 smoke brown
CGC 36 black - triplex opal
CGC 602 black - transparent
CGC 38 opaline
CGC 23 transparent

TEXTILE CABLES

CECL 521 white
CECL 606 yellow
CECL 530 red
CECL 520 gray
CECL 519 black

SURFACE

CCS 518 European oak natural waxed
CCS 657 European oak un-treated
CCS 592 European oak tinted black









Muffin lamps convey a truly extraordinary lighting experience. Their puffy, round shapes and combination of traditional hand-blown tinted glass, oak, and gentle light fill any space with a special aura. The singular design and exceptional quality of the Muffin lamps caught the attention of Yves Saint Lorraine, which used them in a TV advertisement for its 2011 men's collection. The Muffin collection comprises three basic variants – floor, ceiling, and table – that can be fitted with a wooden shade as well as different glass shades in subtle tones of grey, brown, violet etc.

MUFFINS

COLOUR

GLASS

- (glossy CGSU 66)
- CGC 23 transparent
- CGC 39 triplex opal
- CGC 38 opaline
- CGC 540 cognac
- CGC 515 amber
- CGC 554 violet - transparent
- CGC 516 smoke grey
- CGC 538 smoke brown

TEXTILE CABLES

- CECL 521 white
- CECL 606 yellow
- CECL 530 red
- CECL 520 grey
- CECL 519 black

SURFACE

- CCS 518 European oak natural waxed
- CCS 657 European oak un-treated
- CCS 592 European oak tinted black
- CCS680 European oak tinted white











MEMORY

Playful, amusing, surprising – the Memory collection of ceiling and wall fixtures kindles the imagination and takes the beholder back to the carefree days of childhood. Three sizes and a range of colors allow you to turn your creativity loose in devising various lighting experiences. With the hanging strings serving to switch the lights on and off, there is nothing to interrupt the illusion of real balloons. This is beauty in its simplest and most effective form.



COLOUR

- GLASS**
(glossy CGSU 66)
- CGC 39 triplex opal
- CGC 47 yellow - triplex opal
- CGC 30 light pink - triplex opal
- CGC 580 orange - triplex opal
- CGC 579 red - triplex opal
- CGC 578 green apple - triplex opal
- CGC 601 turquoise - triplex opal
- CGC 28 blue - triplex opal
- CGC 617 grey - triplex opal





The Capsula model is a brilliant pendant light design composed of two convex capsules, one overlapping the other and fusing into a singular form. The design resembles cells or plant seeds and evokes the metaphor of light as the source of life. The combination of a crystal-clear glass outer shell and an internal capsule of colored glass gives rise to an exciting 3D optical effect, while the tubular LED light source casts soft and gentle illumination throughout any interior.

CAPSULA

COLOUR

GLASS/BASIC
(glossy CGSU 66)

top parts
CGC 23 transparent
CGC 516 smoke grey

inside parts

CGCI 682 transparent
CGCI 681 yellow - transparent
CGCI 683 violet - transparent
CGCI 684 dark smoke grey
CGCI 685 smoke grey
CGCI 686 amber

TEXTILE CABLES

CECL 519 black

SURFACE

CCS 592 European oak tinted black



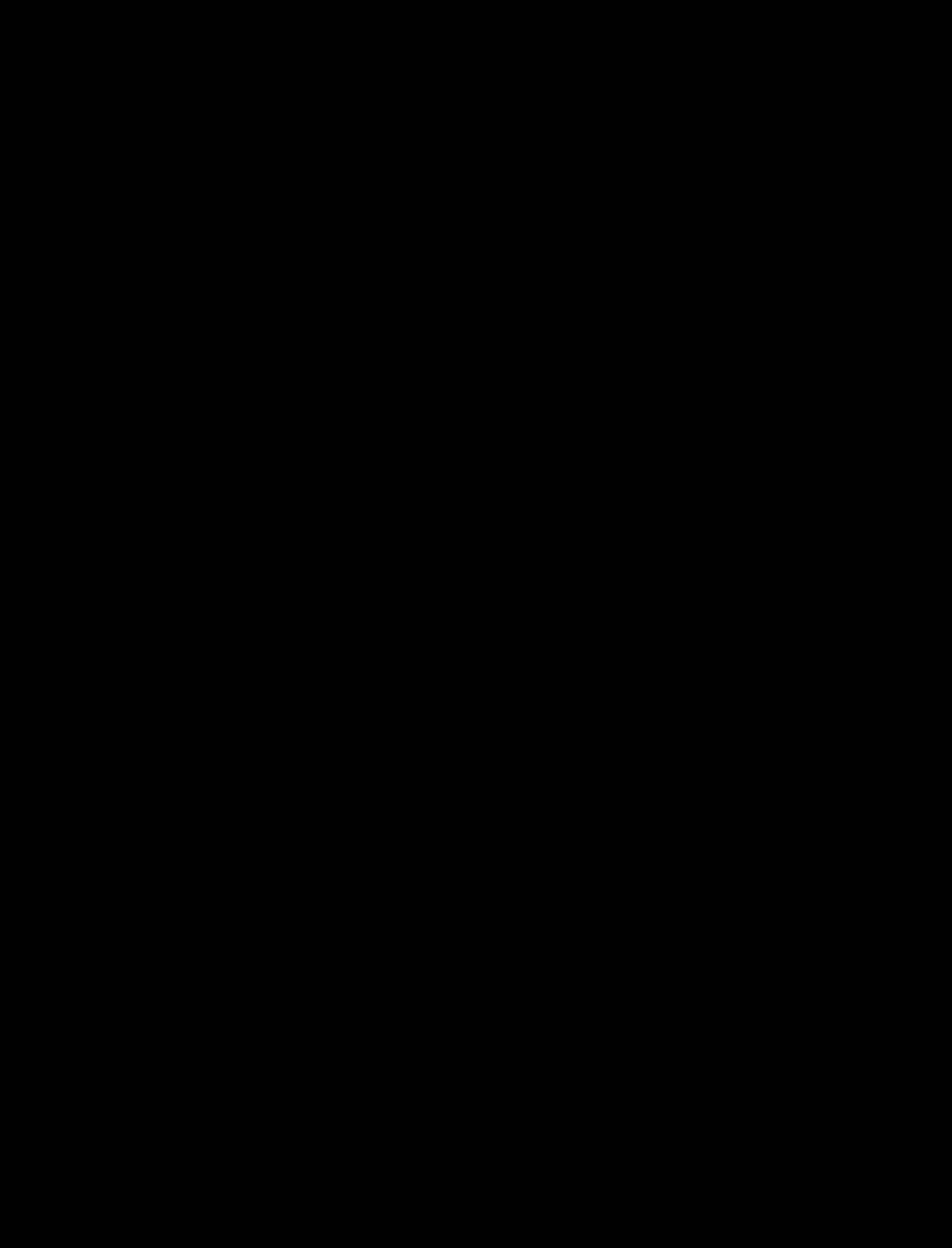





Futuristic bell-shaped Mona lamp demonstrates sensitively the beauty of smooth glass in soft curves. Tubular light source dramatically cuts through the delicate body of the piece and illuminates the design's thrilling tension. The artist's distinctive style is reflected in the unexpected combination of wood, textile, and blown glass. Whilst the sophisticated design of this elegant hand blown lampshade, resembling form of a futuristic helmet, is based on the principle of penetrating forms, previously applied in the design of the Capsula light (Brokis, 2013). The glass shade and textile suspension straps are affixed to the LED light source with a pair of elegant wooden buttons.

MONA



COLOUR

GLASS
(glossy CGSU 66)
CGC 23 transparent
CGC 38 opaline
CGC 516 smoke gray
CGC 602 black - transparent

TEXTILE STRAPS
CCS 678 black
CCS 679 white

SURFACE

CCS 657 European oak un - treated
CCS 518 European oak natural waxed
CCS 592 European oak tinted black
CCS 680 European oak tinted white
CCS 727 Aluminium base





WHISTLE

Suspension Whistle lamp constitutes a symbiosis of two different forms or their multiplication. As the external shape is following the ray of light, it symbolically portrays the shape of traditional whistles. Inserted spot lamp is highlighted by offset inks, outer form creates an impression of the shade of an internal soul of the pendant and further define the precise shape of elongated pipes. Hand-blown objects create a visual line of archetypal lights directing light downwards. Whistle lamp collection consists of three glass pipes of larger dimensions and showcases the mastery of the material and the Czech glassmakers.



COLOUR

GLASS/BASIC

CGC 516 smoke grey
CGC 23 transparent

SPOTLIGHT/BASIC

CCS 575 white
CCS 582 black
CCS 724 magenta
CCS 723 menthol
CCS 720 grey

TEXTILE CABLES

CECL 521
CECL 519
CECL 726
CECL 725
CECL 520





BALLOONS

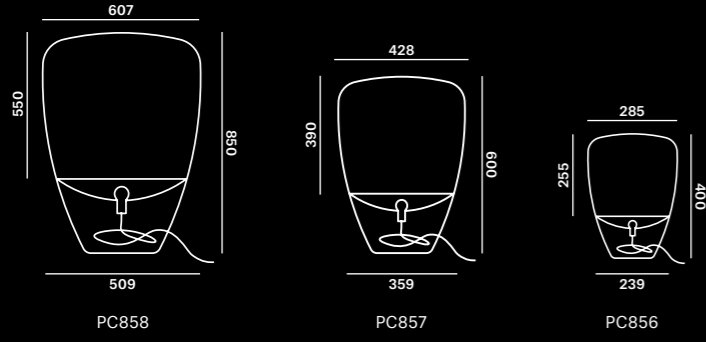

SHADOWS

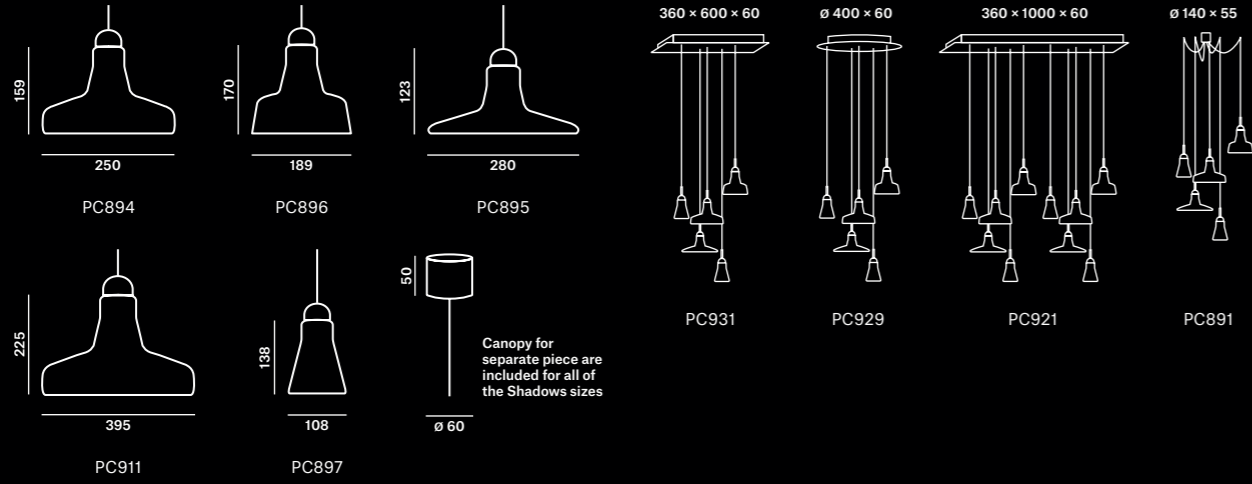

MUFFINS

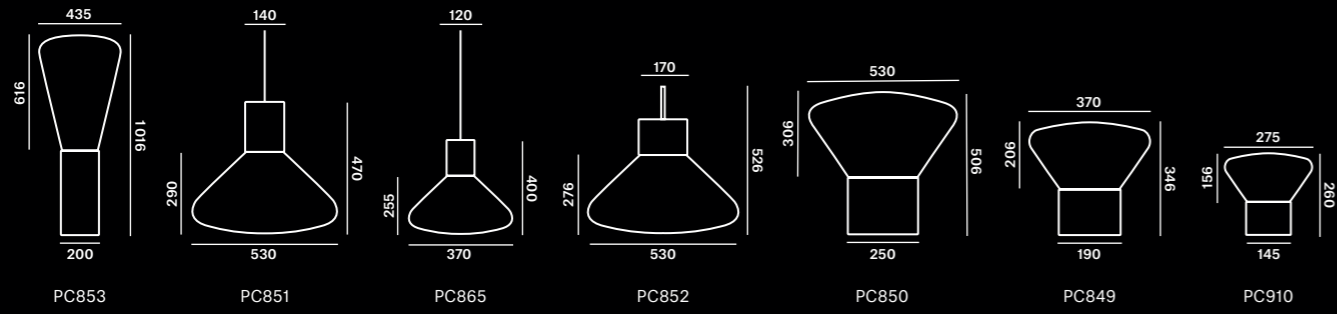

MEMORY

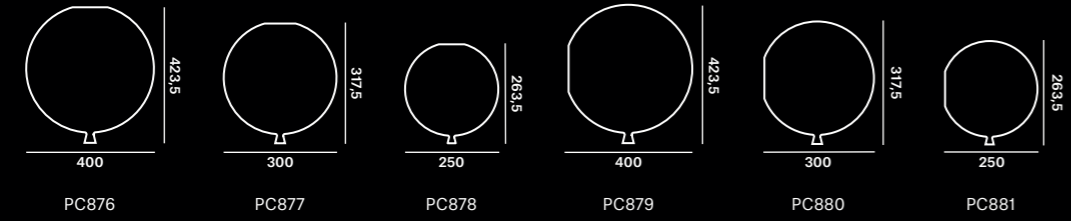

CAPSULA

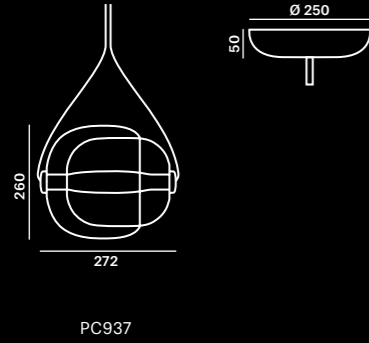

MONA

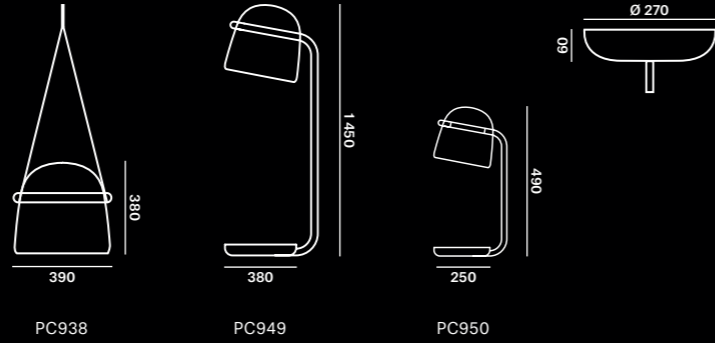

WHISTLE

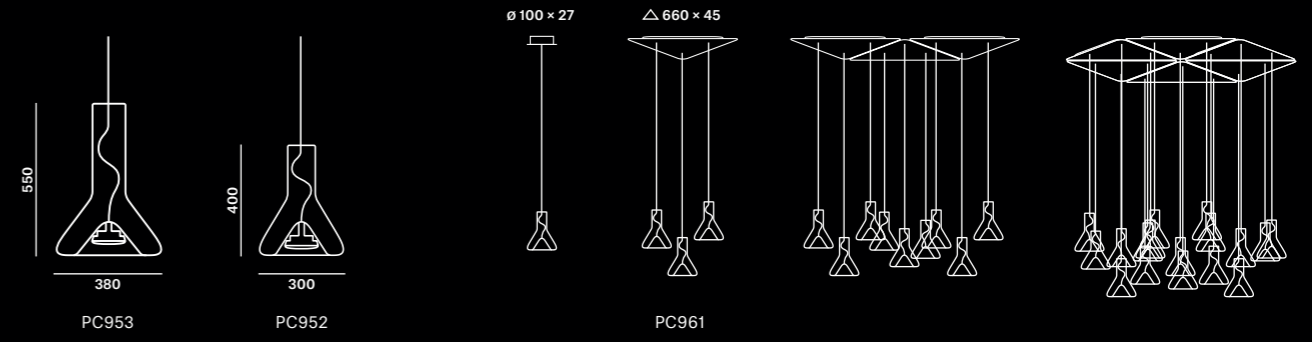

PHOTO
Martin Chum

GRAPHIC DESIGN
Studio Marvil

PRODUCT DESIGN
Creative direction
Lucie Kaldova

DESIGNERS
Lucie Kaldova
Dan Yeffiet
Boris Klimek

BROKIS

OFFICE Španielova 1315/25
163 00 Prague 6, Czech Republic
SHOWROOM Sídliště Janštein 39
588 52 Horní Dubenky
Czech Republic
T +420 567 211 517
F +420 567 211 727
E order@brokis.cz
W www.brokis.cz

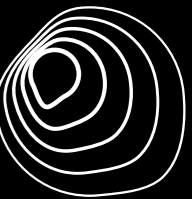

BROKIS

